

HCH-A 中空标准三爪卡盘带安装盘

3-Jaw Open-Center Chuck with adaptor (165mm - 304mm)



■ 3-jaw wedge-style power chuck with adaptor plate

■ 三爪楔形动力卡盘带安装盘

HYDRAULIC CHUCK

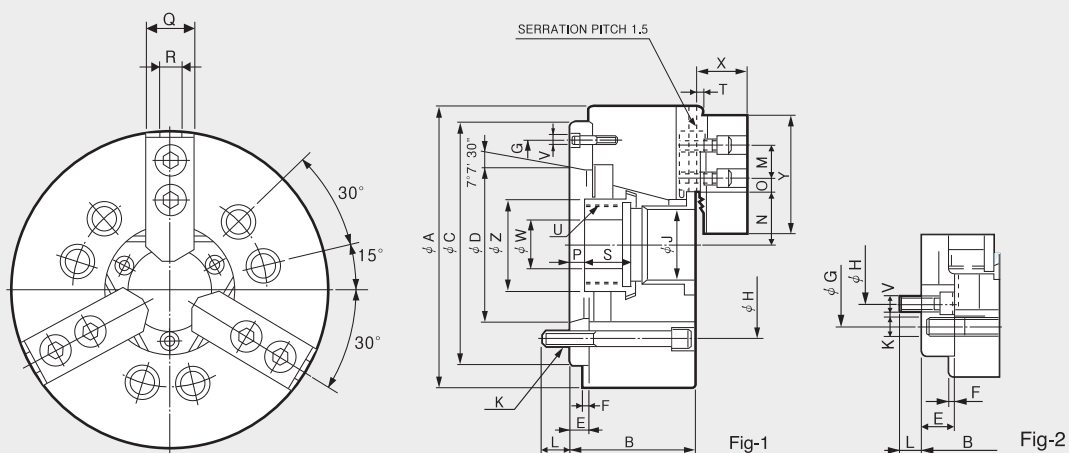

It is recommended to grease chucks at least twice a day in order to maximize longevity.
为了延长寿命 建议一天润滑2次。

Dimensions

	ΦA	B	ΦC(H6)	ΦD	E	F	ΦG	ΦH	ΦJ	K	L	M	Nmax.	Nmin.	Omax.	Omin.	Pmax.	Pmin.	Q	R	S	T	Umax.	V	ΦW	X	Y	ΦZ
HCH-12A06	304	129	220	106.375	25	6	171.4	133.4	78	6-M16x110	18.5	30	58	52.7	48.75	12.75	33	10	49	18	38	5	M88x2.0	6-M12	50	53.5	129	96
HCH-12A08	304	122	220	139.719	18	6	190	171.4	78	6-M16x130	25	30	58	52.7	48.75	12.75	26	3	49	18	38	5	M88x2.0	3-M8	50	53.5	129	96
HCH-15A08	381	160	300	139.719	33	6	235	171.4	117.5	6-M20x130	24	43	82	76.7	43.75	18.25	44	21	62	22	39	5	M130x2.0	6-M16	60	70	165	139
HCH-15M1	381	149	300	196.869	22	6	260	235	117.5	6-M20x150	28	43	82	76.7	43.75	18.25	33	10	62	22	39	5	M130x2.0	3-M10	60	70	165	139
HCH-18A11	450	149	380	196.869	22	6	320	235	117.5	6-M20x150	28	43	82	76.7	78.28	18.25	33	10	62	22	39	5	M130x2.0	3-M10	60	70	165	139

※ Blank and machined draw-nuts are available.

※ "U" is Max. Draw nut size.

※ Refer to Fig-2 for HCH-12A06, HCH-15A08.

※ 提供毛坯和机加拉力螺母。

※ "U" 是拉杆螺母(Draw Nut)最大值。

※ HCH-12A06, HCH-15A08 请参阅 图-2。

Specifications

Type	Spindle Nose No.	Thru Hole Dia.	Grip Dia. [mm]	Jaw Stroke Dia.	Plunger Stroke	Max. Permissible Input Force	Max. Static Gripping Force	Max. R.P.M.	Weight	GD ²	Operating Cylinder	Max. Hydraulic Pressure	Operating Hard Jaw	KITAGAWA® Model
	心轴鼻 球编号	通孔直径	通孔直径	卡爪冲程直径	柱塞冲程	允许输入力	最大静态夹持力	最大转速	重量	容许工作惯性	工作缸	最大液压力	工作硬爪	北川型号
		[mm]	Max. Min.	[mm]	[mm]	[kN(kgf)]	[kN(kgf)]	[min ⁻¹ (r.p.m.)]	[kgf]	[N·m ² (kgf·m ²)]		[Mpa(kgf/cm ²)]		
HCH-12A06	A2-6	78	304	19	10.6	23	49(4997)	129(13150)	3000	69	31.38(3.20)	SYH-2091	2.3(23.5)	HB12B1 B-12A6
HCH-12A08	A2-8	78	304	19	10.6	23	49(4997)	129(13150)	3000	66	30.79(3.14)	SYH-2091	2.3(23.5)	HB12B1 B-12A8
HCH-15A08	A2-8	117.5	381	30	10.6	23	71(7240)	180(18355)	2500	134	96.89(9.88)	SH-25011	2.3(23.5)	HB15A1 B-15A8
HCH-15A11	A2-11	117.5	381	30	10.6	23	71(7240)	180(18355)	2500	127	93.55(9.54)	SH-25011	2.3(23.5)	HB15A1 B-15A11
HCH-18A11	A2-11	117.5	450	30	10.6	23	71(7240)	180(18355)	2000	178	187.30(19.1)	SH-25011	2.3(23.5)	HB15A1 B-18A11

※ Maximum turning speed is based upon actual measurement.

※ Specifications are subject to change without notice.

※ Samsully Machinery Co., Ltd. is no longer an OEM manufacturer for Kitagawa® Iron Works Co., Ltd.

※ 最大转速基于实际测量。

※ 技术规格若发生改变, 恕不另行通知。

※ 三千里机械已结束与日本北川OEM生产。

HCH-A 中空标准三爪卡盘带安装盘

3-Jaw Open-Center Chuck with adaptor (381mm - 610mm)



■ 3-jaw wedge-style power chuck with adaptor plate

■ 三爪楔形动力卡盘带安装盘

HYDRAULIC CHUCK

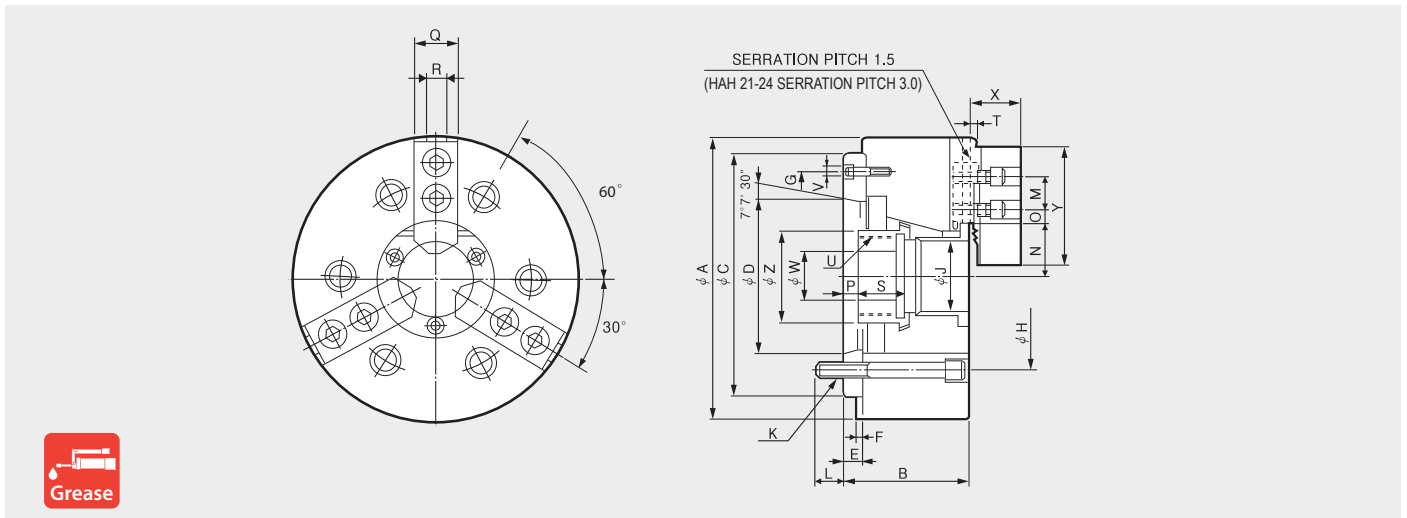

It is recommended to grease chucks at least twice a day in order to maximize longevity.
为了延长寿命 建议一天润滑2次。

Dimensions

	ΦA	B	ΦC(H6)	ΦD	E	F	ΦG	ΦH	ΦJ	K	L	M	Nmax.	Nmin.	Omax.	Omin.	Pmax.	Pmin.	Q	R	S	T	Umax.	V	ΦW	X	Y	ΦZ
HCH-21A15	530	161	380	285.775	27	6	330.2	330.2	140	6-M22x170	34	60	98.5	93.2	87.5	21.5	38	15	65	25	39	5	M155x3.0	3-M12	80	72	180	170
HCH-24A15	610	170	380	285.775	27	6	330.2	330.2	165	6-M22x180	35	60	108	102.7	117.5	21.5	47	24	65	25	40	5	M175x3.0	3-M12	80	72	180	187

※ Blank and machined draw-nuts are available.

※ "U" is Max. Draw nut size.

※ HCH-21A15 and HCH24A15 are available with M22 or M24 mounting bolts.

※ 提供毛坯和机加拉力螺母。

※ "U" 是拉杆螺母(Draw Nut)最大值。

※ HCH - 21A15 跟 HCH - 24A15 可使用M22或 M24 安装螺栓。

Specifications

Type	Spindle Nose No. 心轴鼻 编号	Thru Hole Dia. 通孔直径	Grip Dia. [mm] 通孔直径	Jaw Stroke Dia. 卡爪冲程直径	Plunger Stroke 柱塞冲程	Max. Permissible Input Force 允许输入力	Max. Static Gripping Force 最大静态夹持力	Max. R.P.M. 最大转速	Weight 重量	GD ² 容许工作惯性	Operating Cylinder 工作缸	Max. Hydraulic Pressure 最大液压力	Operating Hard Jaw 工作硬爪	KITAGAWA® Model 北川型号
		[mm]	Max. Min.	[mm]	[mm]	[kN(kgf)]	[kN(kgf)]	[min.-(r.p.m.)]	[kgf]	[N·m ² (kgf·m ²)]		[Mpa(kgf/cm ²)]		
HCH-21A15	A2-15	140	530 87	10.6	23	90(91770)	234(23861)	1700	246	362.83(37.0)	SH-25011	3.0(30.6)	HB18B2	B-21A15
HCH-24A15	A2-15	165	610 110	10.6	23	90(9177)	234(23861)	1400	304	660.94(67.4)	SYHL-2816	3.0(30.6)	HB18B2	B-24A15

※ Maximum turning speed is based upon actual measurement.

※ Specifications are subject to change without notice.

※ Samsully Machinery Co., Ltd. is no longer an OEM manufacturer for Kitagawa® Iron Works Co., Ltd.

※ 最大转速基于实际测量。

※ 技术规格若发生改变, 恕不另行通知。

※ 三千里机械已结束与日本北川OEM生产。